

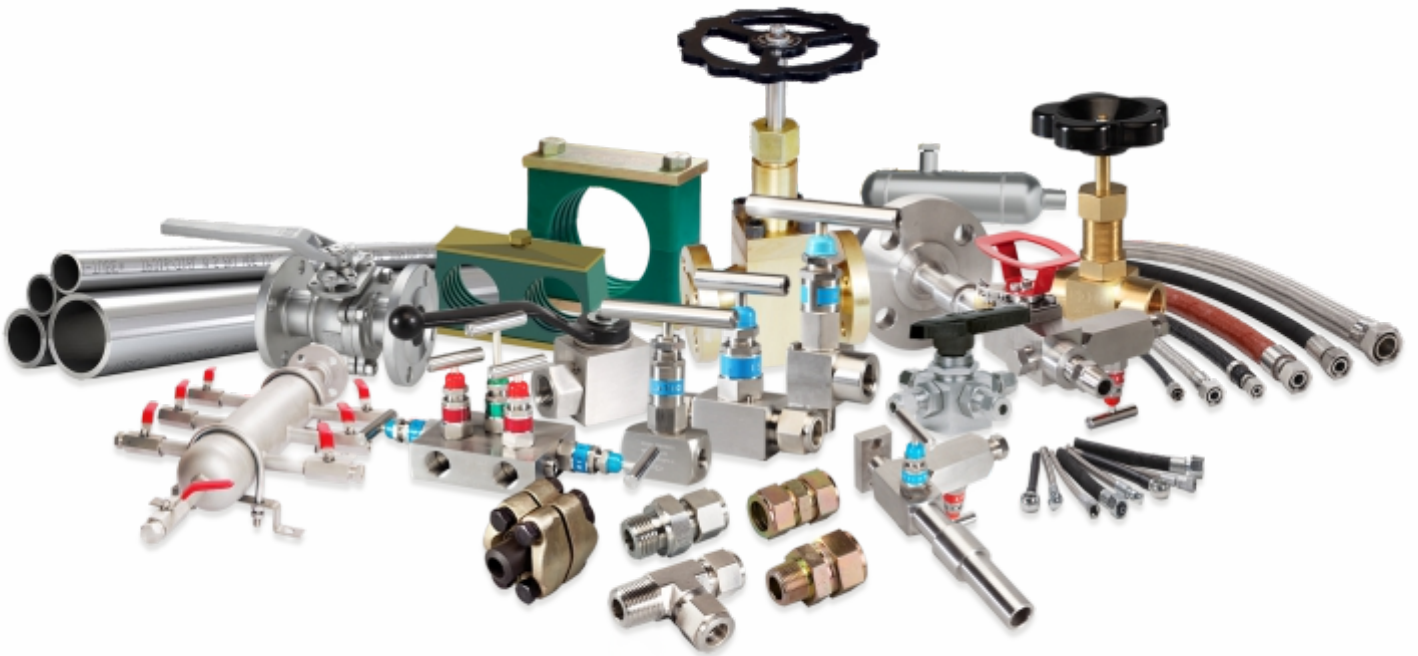

## ENGINEERING FLOW CONTROL

Fittings, Valves, Manifolds, Assemblies,  
Engineering/Testing Services





50 YEARS OF FOCUS ON DESIGN  
FOR CUSTOMER NEED AND  
PRODUCT PERFORMANCE



## OUR COMPANY

Fluid Controls® was established in 1974 by Dr. Y. E. Moochhala, a Ph.D. from Northwestern University, with a vision to deliver high quality and high performance products which delight customers. With 50 years of experience engineering connections, Fluid Controls® offers end-to-end “Make in India” solutions for various applications – from design & engineering services to product supply and installation.

## OUR PRODUCTS & SERVICES

Fluid Controls® offers clients a complete range of instrumentation products - connectors and adaptors for tubes and hose, valves, manifolds, and support accessories. We also offer prefabricated instrument hook-ups, high pressure valves, gas valves for turbine applications, O2 clean fittings, and tube and hose assemblies. Our value-added services include design and testing services and site installation.

## OUR CLIENTS

Fluid Controls® supplies to onshore and off-shore oil and gas installations, process and power plants and the rail/metro industry in India. We are approved by all leading OEM's, including ONGC (offshore/onshore), NTPC, NPCIL, BHEL, GAIL, SAIL, IOCL, Indian Railway OEM's, Alstom Transport, WABTEC. We have over 25 years of expertise in overseas sales to clients in North America, Europe, the Middle East and South East Asia.

## OUR QUALITY ETHOS

### CUSTOMER DELIGHT

### RIGOROUS TESTING & CERTIFICATION PROGRAM

### NO COMPROMISES



## OUR RESEARCH & DEVELOPMENT

Fluid Controls® offers clients customized solutions based on analytical formulations, 2D and 3D Modelling and Finite Elements Analysis. Our commitment to product upgradation and new product development has resulted in the recognition of Fluid Controls® as an “In-House R&D Center” by the Department of Scientific & Industrial Research (DSIR). We have developed over 25 new products in recent years and have been awarded our first Global Patent (and disclosures for two more patents have been filed).

## OUR TESTING & CERTIFICATIONS

The Fluid Controls Test Laboratory is accredited with NABL Certification in accordance with ISO/IEC 17025:2017. The Laboratory houses state-of-the-art performance testing and metrology equipment, capable of conducting high pressure, vibration and reliability tests. Fluid Controls® is systems certified for ISO 9001:2015, ISO 14001, ISO 18001, and PED, product performance certifications include ASTM F1387-99 (2012), ISO 19879 (ISO 8434), NGV, ISO 15500, ECE R110, PDA for Din Single Ferrule Fittings, American Bureau of Shipping PDA for Fittings, Valves and Manifolds, MSS-SP-99, Valves Certifications for API 607 and Fugitive Emission. We also have special certificates to IEC and EN standards for corrosion and shock/vibration for fittings.

## OUR ACHIEVEMENTS

- Recognition as one of the Top 25 Innovative Companies of Year at CII Industrial Innovation Awards 2019 and 2021
- CII Industrial Innovation Award for Medium Scale Manufacturing 2019
- National Winner for Quality Innovation Award by the Indian Society of Quality 2021
- Most Innovative Product by Emerging Enterprise at BWEmerging Businesses Awards 2021
- India 5000 Best MSME Award for Quality Excellence 2020
- Excellence in Technical Innovation by ISA Maharashtra Section at PPA Meet 2020





# FLUID CONTROLS<sup>®</sup>

ENGINEERING CONNECTIONS EVERYDAY



## DOUBLE FERRULE FITTINGS ▶

- Range of Double Ferrule Compression Tube Fittings
- PDA by American Bureau of Shipping (ABS)
- Performance tested to ASTM F1387-99 (2012). Comply with vibration norms of BS EN 61373 and corrosion resistance of IEC 60068-2-52
- Certified for CNG applications (NGV 3.1, ECE R110, ISO 15500)
- Clean Fittings conforming to ASTM G93 level C
- Working pressure as per ASME B31.3 performance temperature to 350°C
- End connections and materials to customer requirements, sizes up to 2 inches
- Heat code traceability



## DIN SINGLE FERRULE FITTINGS ▶

- Design standards DIN 2353 / ISO 8434-1 offered in Light, Medium and Heavy Series
- Performance certified as per ISO 19879 / ISO 8434-5
- Cyclic Endurance, Fire Endurance, Pull Out Tested to IACS P211:2001, Salt Mist Test Performance to ISO 9227
- Unique hardening process for the ferrule developed in-house
- End connections as per customer requirements
- Available in stainless steel, carbon steel provided on request
- Heat code traceability



## NEEDLE VALVES ▶

- A wide variety of designs including two-way, three-way, multi-port, block & bleed
- Specially designed, adapted and certified low temperature valves offering safe, efficient service for temperature to  $-196^{\circ}\text{C}$  ( $-320^{\circ}\text{F}$ )
- Needle Valve PDA by American Bureau of Shipping (ABS). Certified MSS-SP-99, Fugitive Emission Certification as per API 622 / ISO 15848
- Certified for CNG applications (NGV3.1, ECE R110, ISO 15500)
- IBR certification offered
- Working pressure up to 15,000 psig (1034 bar)
- Case hardened non-rotating swiveling plug or ball and thread above the seal design
- End connections and valve material to customer requirements
- Heat code traceability



## HIGH PRESSURE NEEDLE VALVES ▶

- Specially designed range of valves designed for pressures up to 30,000 psig (2.112 bar)
- Case hardened non-rotating swiveling plug / ball and thread above the seal design
- End connections to customer requirements
- Valves offered in stainless steel / nickel alloys
- Heat code traceability



## INSTRUMENTATION MANIFOLDS ▶

- Two, Three and Five Valve Manifolds
- Separately mounted, direct mounted (T Type, H Type), co-planar and flanged configurations
- Working pressure up to 10,000 psig (689 bar)
- IBR certification offered
- Case hardened non-rotating swiveling plug / ball and thread above the seal design
- End connections and material to customer requirements
- Heat code traceability

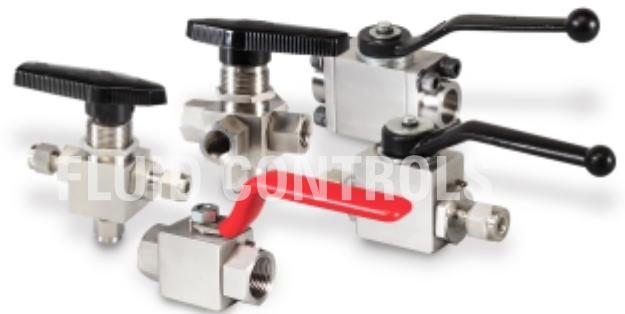

## BALL VALVES ▶

- Standard Two, Three and Four-Way designs
- Switching service ball valves offered in a compact design
- PDA by American Bureau of Shipping (ABS). Fire Safe Certifications as per API 607 / ISO 10497
- Certified for CNG application (NGV 2.1, ECE R110, ISO 15500)
- Special range of flanged end ball valves offered for hydraulic service
- Working pressure up to 10,000 psig (689 bar)
- End connections and material to customer requirements
- Heat code traceability



## GAS VALVES ▶

- A range of special valves designed for:
  - ▶ Hydrogen cooling system of turbo generators
  - ▶ Super-heated steam line including special manifolds
  - ▶ Heat exchangers in condensate lines
  - ▶ Cooling towers
- Globe Valves offered up to NB 150
- Helium leak testing as per customer requirements
- Heat code traceability



## NON RETURN VALVES ▶

- PDA by American Bureau of Shipping (ABS)
- Offered a variety of designs with screwed and tube end connections
- Standard cracking pressure 0.3-0.5 kg/cm<sup>2</sup>
- Cracking pressure up to 2 Kg/cm<sup>2</sup> offered for special applications
- Working pressure up to 6,000 psig (414 bar)
- Valve materials to customer requirements
- Heat code traceability



## PRE-FABRICATED INSTRUMENT HOOKUPS ▶

- EIL approved Pre-fabricated Instrument Hookups
- Each Hookups is custom designed for the customer / application requirement for temperature, flow pressure and working conditions
- 3D and PDMS/PDS modelling to facilitate alignment with the plant layout
- Complete traceability-based compliance to quality control documents
- Simplified packaging per TAG numbers
- On-site assistance during installation



## CLAMPS & FLANGES ▶

- Pipe & Tube Clamps: Standard and Heavy Duty Clamps & Twin Clamps as per DIN 3015 -3. Available in polypropylene, polyamide and aluminum with CS / SS metallic parts
- SAE Flanges designed as per ISO 6162 with butt-weld and socket-weld connections
- CETOP Flanges designed as per ISO 6164 with butt-weld and socket weld end connections and square clamping



## ENGINEERING, INSTALLATION & TESTING SERVICES ►

- Engineering Services:**  
 Include in-depth FEA studies for customers with 3D Modeling/Analysis of performance criteria such as pressure, vibration, reliability life estimation, energy absorption.
- Onsite Installation Services:**  
 Teams of highly-trained resident engineers and fitters manage product inventory, tube formation, swaging/crimping and fitment. Complete supervision until testing and works completion stage.
- Testing Services:**  
 Standard & customized testing offered at the Fluid Controls NABL accredited laboratory (ISO/IEC 17025:2017). Testing offered includes product performance validation testing, metallurgical testing, and non-destructive testing.



## ENGINEERED TUBE & HOSE ASSEMBLIES ►

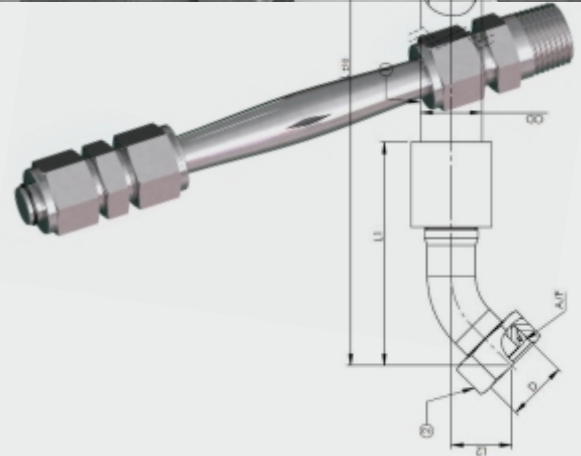
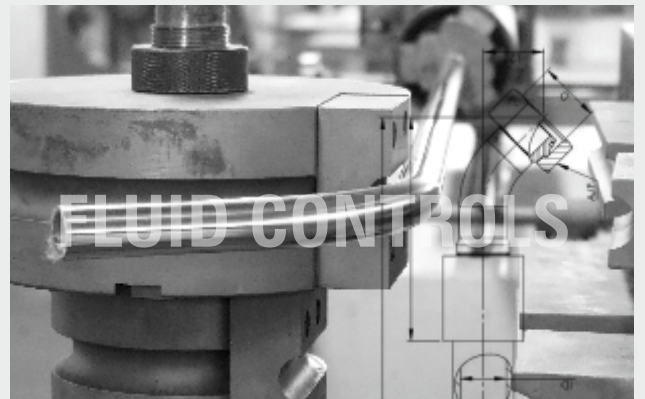

- Engineered and integrated assemblies for hose and tube to customer specifications
- Facilitate customer inventory management and ensure faster turnarounds
- Each assembly required is designed in-house and undergo 3D modeling, FEA and prototyping prior to bulk production
- Tube bending by 5 Axis CNC machine and all bends are CMM measured. End connector swaging by in-house experts
- Hoses sourced from approved vendors. Connectors, crimping and assembly are in-house operations.
- Each assembly is tested prior to despatch
- On-site fitment of sub-assemblies or site supervision is provided if required



## FLUID CONTROLS PRIVATE LIMITED

📍 **Corporate Address:** 5<sup>th</sup> Floor, The International, 16 Maharishi Karve Road, New Marine Lines, Mumbai 400 020, INDIA

☎ **Tel.:** +91-22-6823 8000 | 📠 **Fax:** +91-22-6823 8001

✉ **E-commerce:** [sales@fluidcontrols.com](mailto:sales@fluidcontrols.com) 🌐 **Website:** [www.fluidcontrols.com](http://www.fluidcontrols.com)